

TSCA 65 D

AUTOMATIC SEALING/ CLIPPING MACHINE



Poly-clip System Exclusive Features

The star indicates features that you will only find at Poly-clip System.

- ★ No one else has it: Automatic adjustment of clip pressure and displacer
- ★ No one else has it: Automatic monitoring of clip and die (RFID)

Why clip with TSCA 65 D?

All pasty products, such as adhesives, sealants and explosives as well as dental compounds, fillers and 2-component products are automatically packed – clean and safe. Fluids, such as, for example, injector cream, can also be reliably processed. The TSCA 65 D (automatic sealing/clipping machine) forms roll stock film into a ready-to-be-filled tube which is formed around the stuffing horn and is safely closed by the integrated clipping head to form a clip-pak®.

Cost-reducing investment

- A packaging unit for tight sealing of film and safe clip closure
- For all pasty products, such as adhesives, sealants and explosives
- Reliable, tight clip closure for longer shelf life compared to cartridges due to air-free filling directly into final package
- Measuring out device can be integrated
- Solvent sealed packaging
- Simple and safe marking of batches during production by continuous printing on flat film using an integral printer, e.g. ink jet, hot stamping, thermal transfer

Excellence in Clipping



DETAILS



Efficient packaging of e.g. adhesives, sealants and explosives using the TSCA 65 D

Advantages

- Processes all current types of film, coated and uncoated, as well as sandwich film

Advantages sealing

- Cost-effective packaging solution with minimal use of material
- Processes all current types of film, coated and uncoated, as well as sandwich film
- Continuous production – film rolls up to 2,300 m (65 µm)
- Optimum use of material due to minimum overlap of film at the seam
- Considerably less waste compared to cartridges and other packaging
- Less storage area required for input stocks
- Easy adaptable to folded seam (Finseal)
- Shorter fitting times for a wide variety of pack sizes, thanks to quick-change format set

Advantages clipping

- Savings in packaging material up to 60 % compared to disposable cartridges
- Automatic, self-monitoring processes (clip, film, metering pump, etc.)
- Auto-Stop System, clip sensor monitoring end of clip supply on reel
- Automatic film transport through product feed
- Multiple dosing for high product volumes
- Safe and simple to run, easy to clean design for low operating costs
- One central display – reliable control of all production processes
- die Produktparameter sind in der Rezepturverwaltung des SAFETY TOUCH abrufbar
- Highly dynamic, energy-efficient servo drive, infinitely adjustable speed
- Simple machine operation with SAFETY TOUCH – shock-proof, 10" large and easy to clean

- Operator-friendly with individually assignable manual functions, e.g. inching mode
- R-ID clip with high holding force, even up to bacteria-proof clip closure with plastic and sandwich films
- Incorrect settings are avoided by detection of the clip size and die
- Compact, space-saving design for easy handling
- Easy access for maintenance and service through large doors



The TSCA 65 D heat-sealing station

- Excellent price/performance ratio
- Maximum use of material due to firm filling, even with sandwich films
- Short, clean clip-pak® product ends due to voiding separator
- Safe and tight clip closure without damage to film
- Product protection by tamper-proof closure

Quality and hygiene

- Easy to clean, closed system, only one part product-carrying (stuffing horn)
- Stainless steel provides resistance to aggressive cleaning solutions

Equipment options

- Connectivity towards dosing pumps of almost all known manufacturers
- Product identification with integrable printer, e.g. ink-jet, thermotransfer
- Splice detection for attached films
- Simple and reliable marking of batches during production using printing on flat film or film tube
- Overspreading for loose filling of expandable products
- Quick breakage control with automatic machine stop, standard equipment with HDP 40

Function and operation

The TSCA 65 D consists of a synchronised unit of sealing and clipping machine and builds a continuously operating production line with the upstream filling unit. Both production processes are operator-friendly and can be easily programmed via the central touch panel. Set-up and system control are protected by access codes and set on different levels identified by colour. The machine is operated via five buttons on the operator panel. The film roll is placed on a self-tensio-





TSCA 65 D with HDP 40 (Hydraulic Dosing Pump) used for sealants and adhesives up to 65 mm diameter

ning roll carrier. Uniform inlet tension of the film is achieved by the roller guide system. The forming shoulder forms the flat film around the stuffing horn into an open tube. The tube is then sealed lengthways with minimal overlap by heat sealing. To prevent a runback of the product, the end of the stuffing horn is sealed by an inner calibre ring towards the tube so that even liquid products are filled to a precise preset weight.

Clip System Solutions

The complete system of clipping machine, clips and loops from a single source ensures efficient and trouble-free production. Original clips from Poly-clip System guarantee the highest quality. Manufacturing is subject to the most rigorous quality controls. Certified in accordance with ISO 22000 and ISO 9001 they are designed to suit the production process perfectly. With its food-proof safety coating certified by the SGS INSTITUT FRESENIUS, Poly-clip SAFE-COAT technology

ensures trouble-free production and if required a no-worry product warranty. Poly-clip System is the world's leading provider of clip system solutions.



Volumetric dosing of HDP – high accuracy of filling quantity

TECHNICAL DATA

Front view (dimension in mm)

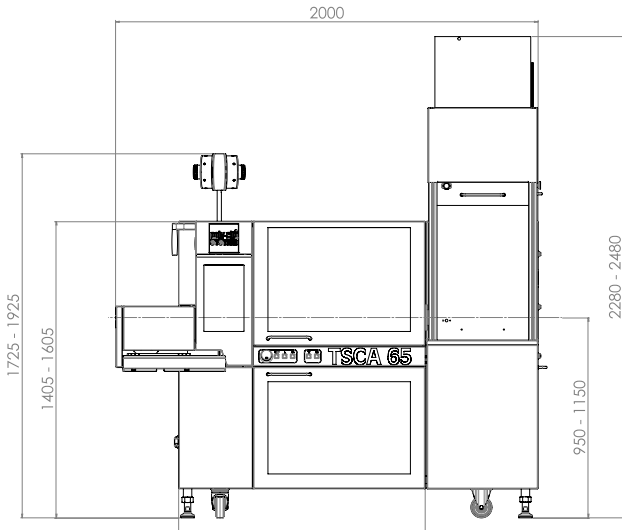

Top view (dimension in mm)

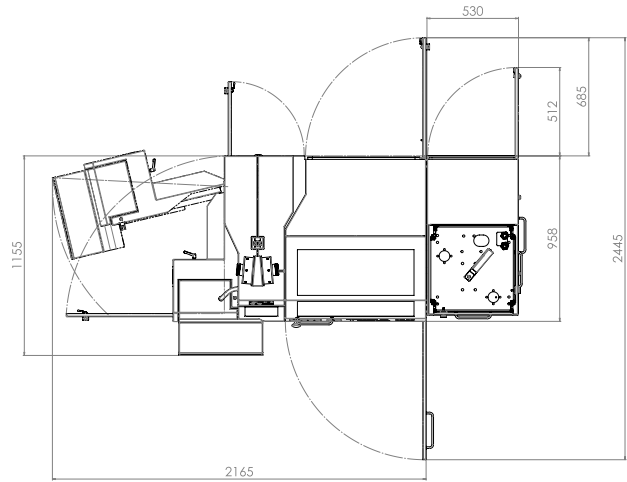

Width
**1.465 –
2.165 mm**

Depth
**1.155 –
2.445 mm**

Height
**1.725 –
1.925 mm**

Weight
790 kg

Three-phase current con-
nection
**200 – 240 VAC,
380 – 460 VAC,
50/60 Hz**

Power input
3,6 kW

Fuse connection
16 A

Compressed air
**5 – 7 bar /
0,5 – 0,7 MPa**

Air consumption
2,5 NL/Cycle

Dimensions, weight and consumption values vary depending on the equipment and/or machine configuration.

Excellence in Clipping

