

TSCA 65 D

Automatic Sealing/Clipping Machine



Cost-reducing investment

- A packaging unit for tight sealing of film and safe clip closure
- For all pasty products, such as adhesives, sealants and explosives
- Reliable, tight clip closure for longer shelf life compared to cartridges due to air-free filling directly into final package

Why clip with TSCA 65 D?

All pasty products, such as adhesives, sealants and explosives as well as dental compounds, fillers and 2-component products are automatically packed – clean and safe. Fluids, such as, for example, injector cream, can also be reliably processed. The TSCA 65 D (automatic sealing/clipping machine) forms roll stock film into a ready-to-be-filled tube which is formed around the stuffing horn and is safely closed by the integrated clipping head to form a clip-pak®.

✓ Advantages

- Processes all current types of film, coated and uncoated, as well as sandwich film

✓ Advantages sealing

- Cost-effective packaging solution with minimal use of material
- Processes all current types of film, coated and uncoated, as well as sandwich film

- Continuous production – film rolls up to 2,300 m (65 µm)
- Optimum use of material due to minimum overlap of film at the seam
- Considerably less waste compared to cartridges and other packaging

Excellence in Clipping



TSCA 65 D

Automatic Sealing/Clipping Machine



Efficient packaging of e.g. adhesives, sealants and explosives using the TSCA 65 D



The TSCA 65 D heat-sealing station



Volumetric dosing of HDP – high accuracy of filling quantity

- Less storage area required for input stocks
- Easy adaptable to folded seam (Finseal)
- Shorter fitting times for a wide variety of pack sizes, thanks to quick-change format set

✓ Advantages clipping

- Savings in packaging material up to 60 % compared to disposable cartridges
- Automatic, self-monitoring processes (clip, film, metering pump, etc.)
- Auto-Stop System, clip sensor monitoring end of clip supply on reel
- Automatic film transport through product feed

- Multiple dosing for high product volumes
- Safe and simple to run, easy to clean design for low operating costs
- One central display – reliable control of all production processes
- Highest productivity; product parameters can be recalled from the SAFETY TOUCH recipe management
- Highly dynamic, energy-efficient servo drive, infinitely adjustable speed
- Simple machine operation with SAFETY TOUCH – shockproof, 10" large and easy to clean
- Operator-friendly with individually assignable manual functions, e.g. inching mode
- R-ID clip with high holding force, even up to bacteria-proof clip

closure with plastic and sandwich films

- Incorrect settings are avoided by detection of the clip size and die
- Compact, space-saving design for easy handling
- Easy access for maintenance and service through large doors
- Excellent price/performance ratio
- Maximum use of material due to firm filling, even with sandwich films
- Short, clean clip-pak® product ends due to voiding separator
- Safe and tight clip closure without damage to film
- Product protection by tamper-proof closure

✓ Quality and hygiene

- Easy to clean, closed system, only one part product-carrying (stuffing horn)
- Stainless steel provides resistance to aggressive cleaning solutions

+ Optional equipment

- Connectivity towards dosing pumps of almost all known manufacturers
- Product identification with integrable printer, e.g. ink-jet, thermotransfer
- Splice detection for attached films
- Simple and reliable marking of batches during production using printing on flat film or film tube
- Overspreading for loose filling of expandable products
- Quick breakage control with automatic machine stop, standard equipment with HDP 40

+ Combinability HDP

The Hydraulic Dosing Pump is designed for low and high viscosity chemical/technical products.

TSCA 65 D

Automatic Sealing/Clipping Machine

The volumetric dosing guarantees high reproducibility of filling weight and process cycle. The TSCA's multifunctional control via touch panel improves the synchronization of the filling process while producing clip-paks®. Thus a higher accuracy of the filling volume is achieved. Quick-fixing systems ensure fast conversion for product changes. The practical design of the dosing unit permits easy disassembly and cleaning.

- Fully automatic weight adjusting, deviations reduced to max. $\pm 0.5\%$.
- HDP 30 or 40, up to 30 resp. 40 cycles/minute, also for high viscosity products.
- Fully automatic weight control by scales with tendency control.

Function and operation

The TSCA 65 D consists of a synchronised unit of sealing and clipping machine and builds a continuously operating production line with the upstream filling unit. Both production processes are operator-friendly and can be easily programmed via the central touch panel. Set-up and system control are protected by access codes and set on different levels identified by colour. The machine is operated via five buttons on the operator panel. The film roll is placed on a self-tensioning roll carrier. Uniform inlet tension of the film is achieved by the roller guide system. The forming shoulder forms the flat film around the stuffing horn into an open tube. The tube is then sealed lengthways with minimal overlap by heat sealing. To prevent a runback of the product, the end of the stuffing horn is sealed by an inner calibre ring towards the tube so that even liquid products are filled to a precise preset weight.

Clip system solutions

The complete system of clipping machine, clips and loops from a single source ensures efficient and trouble-free production. Original clips from Poly-clip System guarantee the highest quality. Manufacturing is subject to the most rigorous quality controls. Certified in accordance with ISO 22000 and ISO 9001 they are designed to suit the production process perfectly. With its food-proof safety coating certified by the SGS INSTITUT FRESENIUS, Poly-clip SAFE-COAT technology ensures trouble-free production and if required a no-worry product warranty. Poly-clip System is the world's leading provider of clip system solutions.

TSCA 65 D with HDP 40 (Hydraulic Dosing Pump) used for sealants and adhesives up to 65 mm diameter



TSCA 65 D

Automatic Sealing/Clipping Machine

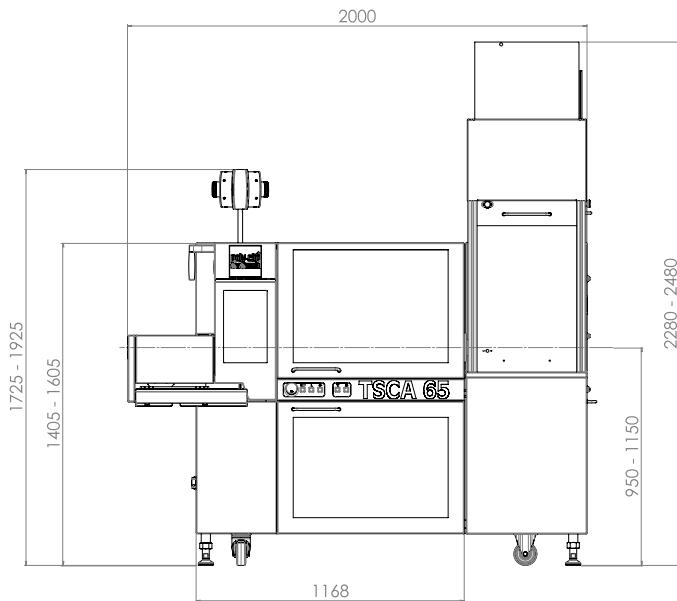

Front view (Dimensions in mm)

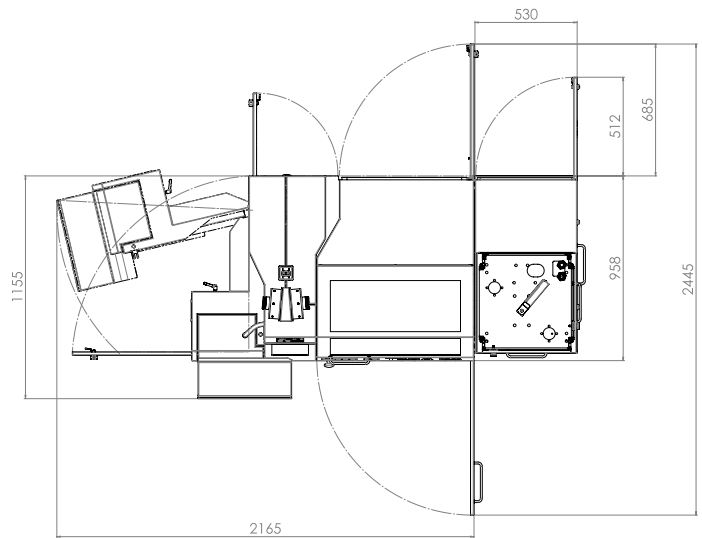

Top view (Dimensions in mm)

Technical data

	TSCA 65 D	TSCA 65 D/HDP 40
Width	1,465–2,165 mm	2,000–2,700 mm
Depth	1,155–2,445 mm	1,155–2,445 mm
Height	1,725–1,925 mm	2,280–2,480 mm
Weight	790 kg	1,365 kg
Three-phase current connection	200–240 VAC, 380–460 VAC, 50/60 Hz	200–240 VAC, 380–460 VAC, 50/60 Hz
Power input	3.6 kW	3.6 kW
Fuse connection	16 A	16 A
Compressed air	5–7 bar / 0,5–0,7 MPa	5–7 bar / 0,5–0,7 MPa
Air consumption	2.5 NL/cycle	2.5 NL/cycle
Dosing volume		700 ml
Hydraulic pressure		160 MPa

Dimensions, weight and consumption values vary depending on the equipment and/or machine configuration.

Poly-clip System GmbH & Co. KG

Niederckerstraße 1 • 65795 Hattersheim a. M. • Germany
Tel. +49 6190 8886-0 • contact@polyclip.de • www.polyclip.com

Excellence in Clipping

