

FCA 90

AUTOMATIC DOUBLE-CLIPPER



Poly-clip System Exclusive Features

The star indicates features that you will only find at Poly-clip System.

- ★ No one else has it: World's fastest automatic machine for moulded products
- ★ No one else has it: Automatic central lubrication

Why clip with FCA 90?

The FCA 90 offers unrivalled versatility. It closes collagen casings up to 90 mm, fibrous casings up to 120 mm and plastic casings up to 160 mm (depending on the material thickness). Chubs, cold cuts, ham with only 10 % injected, tumbled pieces of meat, can be reliably processed.

Air-free slack filling

- Total spreading up to 300 mm for moulded products
- For the 38 – 160 mm calibre range at up to 126 cycles/minute in continuous mode
- Versatility for chubs, cold cuts and ham
- Voiding separator and clip shape optimised for short sausage shoulders and more slices per sausage
- Shaped products up to 1.800 mm long
- Optionally loop on the left or right

Excellence in Clipping



DETAILS



Powerful clipper for large calibres

Advantages

- Change of spreading via SAFETY TOUCH, within the standard spreadings as well as to the overspreading, based on the unique PCS motion controller
- Highest productivity, simple operation and self-monitoring processes of the essential functions
- R-ID Clip with high holding force, even up to bacteria-proof clip closure with plastic casings
- beim Einstellen
- Operating instructions on SAFETY TOUCH. Functions and parameters are explained
- Incorrect settings are avoided by detection of the clip size and die
- Auto-Stop System, clip sensor monitoring end of clip supply on reel
- Uniform pleating and clean sausage tails due to the linear voiding separator
- Highly dynamic, energy-efficient servo drive, infinitely adjustable speed
- Gesamtspreizung 300 mm
- Simple machine operation with SAFETY TOUCH – shock-proof, 10" large and easy to clean
- Operator-friendly with individually assignable manual functions, e.g. inching mode
- die Produktparameter sind in der Rezepturverwaltung des SAFETY TOUCH abrufbar
- Tool free quick-change system of the punch
- Easy external adjustment of the separator hole
- Manual clip pressure setting
- Electronic hand-wheel for adjustments and setting parameters
- Additional safety by two-handed triggering of first clip
- Product true to the calibre by adjustable conveyor speed
- Simple, ergonomic handling for reloading of casing, without swing-out of the clip head
- Easy to manoeuvre with two lockable wheels
- Low noise level
- Compact design

Quality and hygiene

- Robust and of stainless steel design for highest reliability and a long service life
- Easy to clean due to smooth surfaces

Maintenance

- Centralized lubrication strip for easy and fast maintenance
- Optimum access for maintenance work

Equipment options

- Automatic looper GSA 20, loop left or right
- Consumption-oriented central lubrication for maximum reliability and service life
- Sensors for loops and casing end
- Roller conveyor extension up to 1,700 mm
- Vacuum system 48, 60, 76 mm
- WS Food Standard interface for operational data acquisition
- Intelligent Filler Clipper (IFC) Interface upon request
- Twin turret with swivel horns and 90° pivot point
- Casing brake assistant – semi-automatic casing brake holder system for fastest reloading of casings
- Pneumatic dry sausage brake, individual control of the



Casing brake assistant – semi-automatic casing brake holder system

twin turret's casing brakes as product parameter via SAFETY TOUCH

- Second control panel at end of conveyor belt
- Length portioning by means of optical scanning, optional up to 1,300 or 1,800 mm
- Clip coding
- Ball joint filler connection

Consumables

- R-ID Clip: M, L, XL

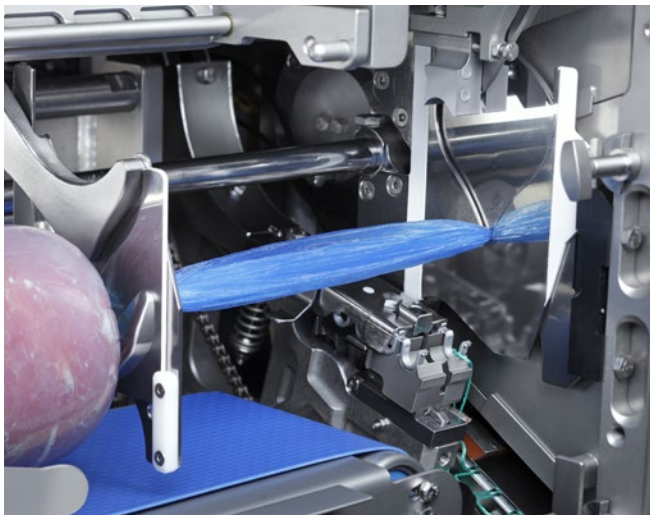

Overspreading for air-free slack filling of moulded products





Versatility for chubs, cold cuts and ham



Retractable automatic looper GSA for easy reloading of loops

Function and operation

The automatic double clipping machine is connected mechanically and synchronized electrically to a filling machine. The portions are fed in precisely to the nearest gram and closed by a clip. The PC control allows a very fast and accurate signal processing. On the SAFETY TOUCH display the diagnostic system provides a direct and clear indication of the clipping machine's operational status as well an analysis of filling and clipping times. Deviations from the recipe parameters saved in SAFETY TOUCH are monitored. The operator is intuitively guided through the flat menu structure of the SAFETY TOUCH by means of self-explaining pictograms. Operator, set-up and service levels are kept clearly separated and are password protected. A continuous process monitoring is offered by the high degree of automation.

Clip System Solutions

The complete system of clipping machine, clips and loops from a single source ensures efficient and trouble-free production. Original clips from Poly-clip System guarantee the highest quality. Manufacturing is subject to the most rigorous quality controls. Certified in accordance with ISO 22000 and ISO 9001 they are designed to suit the production process perfectly. With its food-proof safety coating certified by the SGS INSTITUT FRESENIUS, Poly-clip SAFE-COAT technology ensures trouble-free production and if required a no-worry product warranty. Poly-clip System is the world's leading provider of clip system solutions.



Products true to the calibre due to adjustable conveyor speed

TECHNICAL DATA

Front view (Dimensions in mm)

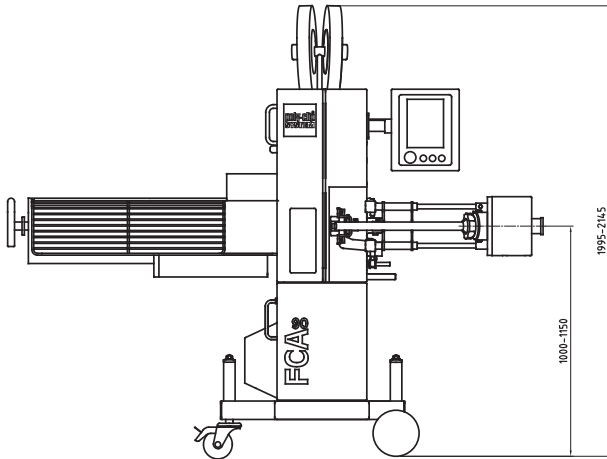

Top view | Length of stuffing horn 600 (Dimensions in mm)

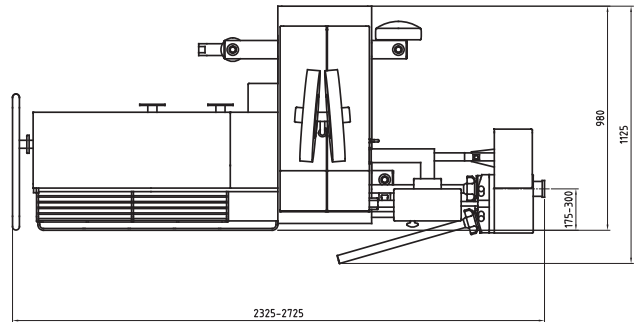

Width
**2.325 –
2.725 mm**

Depth
1.125 mm

Height
**1.995 –
2.145 mm**

Weight
600 kg

Three-phase current con-
nection
**200 – 240 VAC,
380 – 460 VAC,
50/60 Hz**

Power input
7,5 kW

Fuse connection
16 A

Compressed air
**5 – 7 bar /
0,5 – 0,7 MPa**

Air consumption
2,5 NL/Cycle

Spreading
26, 30, 36, 44 mm

Total spreading up to
300 mm

Dimensions, weight and consumption values vary depending on the equipment and/or machine configuration.

Excellence in Clipping

