

FCA 60

AUTOMATIC DOUBLE-CLIPPER



Poly-clip System Exclusive Features

The star indicates features that you will only find at Poly-clip System.

- ★ No one else has it: Linear displacer for symmetrical sausage ends with uniform pleating
- ★ No one else has it: The smallest clip in the world (XS clip)

Why clip with FCA 60?

In the FCA class the FCA 60 is the specialist for small calibres, a robust entry-level machine with simple functions that is easy to operate. The automatic double-clipper closes collagen casings up to 65 mm, fibrous casings up to 48 mm and plastic casings up to 80 mm (depending on the material thickness).

Simply for small calibres

- Especially for snack products
- Basic oriented operation
- For a range of calibres from 18 to 80 mm and up to 125 cycles per minute in continuous mode
- Robust and of stainless steel design for highest reliability and a long service life
- Easy to manoeuvre with two lockable wheels

Excellence in Clipping



DETAILS



Advantages

- Easy clipping optimized to the essentials
- R-ID Clip with high holding force, even up to bacteria-proof clip closure with plastic casings
- Incorrect settings are avoided by detection of the clip size and die
- Auto-Stop System, clip sensor monitoring end of clip supply on reel
- Tool free quick-change system of the die
- beim Einstellen
- Short sausage ends, uniform pleating and clean sausage tails due to the linear voiding separator
- Highest productivity adjustable in three speed levels, additional speed profile for overspreading
- Gesamtspreizung bis 100 mm, manuell einstellbar
- Ergonomic and functional controls for product-specific settings
- Comfortable external adjustment of the separator hole

- Electronic hand-wheel for adjustments, clip loading position, clip pressure and parameter settings
- Additional safety by two-handed triggering of first clip
- Adjustable conveyor belt speed for products true to the calibre
- Simple, ergonomic handling for reloading of casing, without swing-out of the clip head
- Easy to manoeuvre with two lockable wheels
- Low noise level

Quality and hygiene

- Stainless steel provides resistance to aggressive cleaning solutions
- Smooth surfaces, large openings and flaps make for easy cleaning
- Removable separator cleaning cover – allows ideal accessibility

Maintenance

- Extremely compact design for easy serviceability with few wear parts easily accessible
- Centralized lubrication strip for easy and fast maintenance

Equipment options

- Special machine version for rings with adapted front flap and double-conveyor belt 700 mm
- String dispenser for rings
- Conveyor belt, single lane 700 and 1,200 mm, roller extension 1,000 and 1,600 mm, and double-belt 700 mm
- Automatic looper GSA 20
- Comfort setting for spreading and overspreading
- Twin turret with swivel horns
- Casing brake assistant – semi-automatic casing brake holder system for fastest reloading of casings
- Pneumatic casing brake (dry sausage brake)
- Length portioning by means of optical scanning
- Ball joint filler connection
- Sensors for loops and casing end

Possible combinations

ES 5000

- Labelling system for marking and traceability

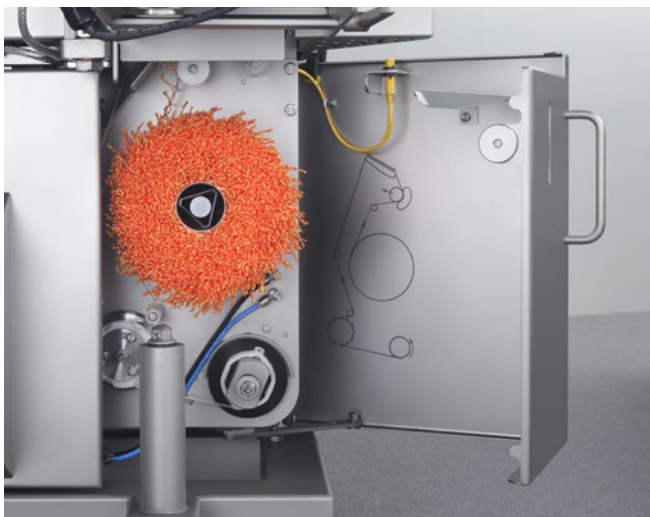

Automatic looper GSA 20 – easy reload of loops

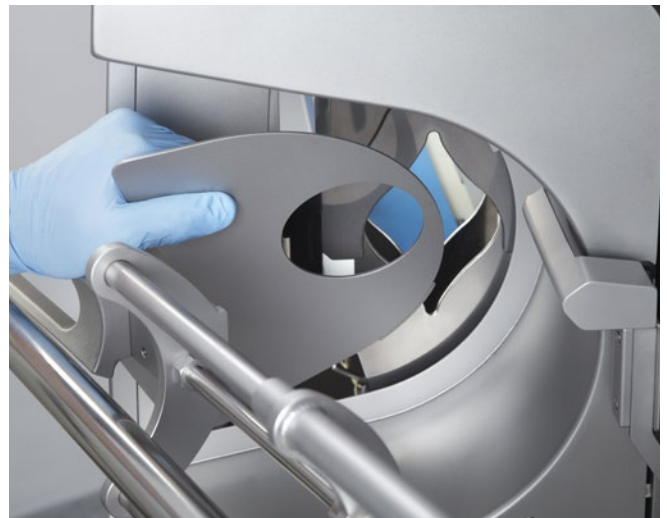

Removable separator cleaning cover

Consumables

- R-ID Clip: XS, S, M

Function and operation

The automatic clipping machine is connected mechanically and electrically to the stuffer. The portions are fed in precisely to the nearest gram and closed by a clip as single portions or chains. The FCA 60 with its controller board is driven by a servo frequency converter. The clear control panel includes





Product outlet with adjustable double-conveyor belt

function keys for the counters knife, loop, label and single clip feature. Reload of casing is simple and comfortable, without swing-out of the clip head.

Clip System Solutions

The complete system of clipping machine, clips and loops from a single source ensures efficient and trouble-free production. Original clips from Poly-clip System guarantee the

highest quality. Manufacturing is subject to the most rigorous quality controls. Certified in accordance with ISO 22000 and ISO 9001 they are designed to suit the production process perfectly. With its food-proof safety coating certified by the SGS INSTITUT FRESENIUS, Poly-clip SAFE-COAT technology ensures trouble-free production and if required a no-worry product warranty. Poly-clip System is the world's leading provider of clip system solutions.



Safety casing brake with hand guard

TECHNICAL DATA

Front view (Dimensions in mm)

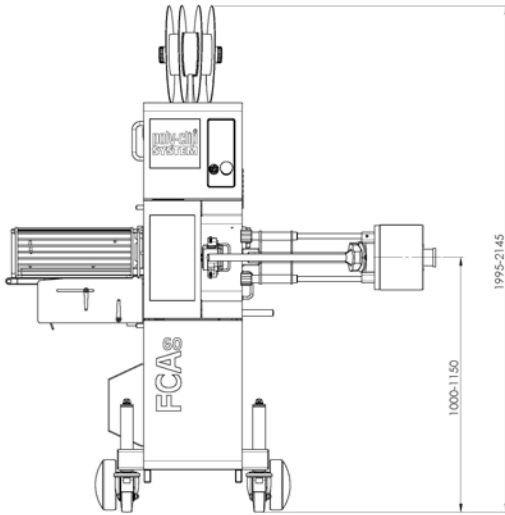

Top view | Length of stuffing horn 600 (Dimensions in mm)

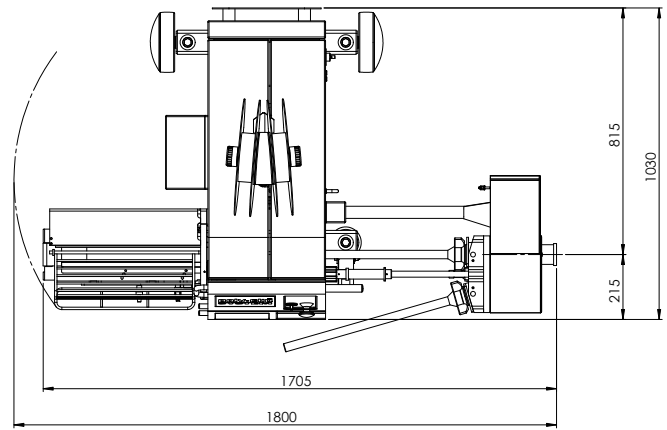

Width
**1.705 –
1.800 mm**

Depth
1.030 mm

Height
**1.995 –
2.145 mm**

Weight
460 kg

Three-phase current con-
nection
**200 – 240 VAC,
380 – 460 VAC,
50/60 Hz**

Power input
4 kW

Fuse connection
16 A

Compressed air
**5 – 7 bar /
0,5 – 0,7 MPa**

Air consumption
2,5 NL/Cycle

Spreading
18, 26, 30 mm

Total spreading up to
100 mm

Dimensions, weight and consumption values vary depending on the equipment and/or machine configuration.

Excellence in Clipping

