



Maximum automation

- For the 24 – 120 mm calibre range at more than 200 cycles per minute in continuous mode
- Highest productivity through automatic, self-monitoring processes
- Voiding separator and clip shape optimised for short sausage shoulders and more slices per sausage
- Consumption-oriented central lubrication for

Why clip with FCA 120?

The FCA 120 is characterised by a maximum speed at more than 200 cycles combined with highest automation. It closes collagen and fibrous casings up to 58 mm and plastic casings up to 120 mm (depending on the material thickness).



Advantages

- Highest productivity through automatic, self-monitoring processes
- Size of the voiding separator and setting of the clip pressure under servo control, can be saved as product parameters
- Incorrect settings are avoided by detection of the clip size, the punch and die
- R-ID Clip with high holding force, even up to bacteria-proof clip closure with plastic casings
- Auto-Stop System, clip sensor monitoring end of clip supply on reel; easy removal of remaining clips
- Uniform pleating and clean sausage tails due to the linear vertical voiding separator
- Highly dynamic, energy-efficient servo drive, infinitely adjustable speed
- Simple machine operation with SAFETY TOUCH – shockproof, 10" large and easy to clean
- Highest productivity; all product parameters can be recalled from the SAFETY TOUCH recipe management
- All recipes can be duplicated,



saved and restored with the SAFETY TOUCH

- Operator-friendly with individually assignable manual functions, e.g. inching mode
- Simple, ergonomic handling



FCA 120 – the specialist machine for high speed production of calibres up to 120 mm



Shortest setup time due to comfort opening of front flap



Overspreading for air-free slack filling of moulded products



Separator cleaning flap



Casing brake assistant – semi-automatic casing brake holder system

- Adjustable conveyor belt speed for products true to the calibre
- Air-free slack filling of moulded products by overspreading, total spreading up to 130 mm
- Low noise level
- USB port for data import and export

✓ Quality and hygiene

- Robustness and long service life guaranteed by use of stainless steel and titanium
- Easy to clean due to smooth surfaces, large openings, front flap and the special separator cleaning position
- Separator cleaning flap – allows ideal accessibility

✓ Maintenance

- Easy access to main connections, electronics and pneumatics
- Maintenance- and service-friendly with few wearing parts, easily accessible by swing-off side covers
- Detailed display of fault messages at a glance
- Simple analysis by filtering the error list, selecting and exporting the messages

+ Optional equipment

- Consumption-oriented central lubrication for maximum reliability and service life
- Automatic looper GSA 20, loop left or right
- Spreading and overspreading servo-assisted
- Casing brake assistant – semi-automatic casing brake holder system for fastest reloading of casings
- Burst detection with automatic machine stop
- Sensors for loops and casing end
- Double-clip detection with fully automatic machine stop

for reloading of casing, without swing-out of the clip head

- Quick-change system for clip spacing without tools and for spreading with just a few hand-grips
- Safety casing brake with hand guard; maintaining safety distance to separator when ad-

justed, operation without casing brake is blocked

- Additional safety by two-handed triggering of first clip
- Operating instructions on SAFETY TOUCH. Functions and parameters are explained
- Electronic hand-wheel for adjustments and setting parameters

- Conveyor belt position recognition on overspreading
- Twin turret with swivel horns and 90° pivot point
- Clean in Place (CIP) for continuous die cleaning
- Pneumatic dry sausage brake, individual control of the twin turret's casing brakes as product parameter via SAFETY TOUCH
- Length portioning by optical sensor or mechanical length stop 1,000 mm and 1,350 mm
- String dispenser for rings
- Print mark control for centred printing format
- Ball joint filler connection
- Fully hygienic conveyor belt, dismantling without tools, single lane 700 or 1200 mm, double-belt 700 mm and roller extension
- USB port for data import and export
- WS Food Standard interface for operational data acquisition
- Intelligent Filler Clipper (IFC) Interface upon request

+ Combinability

ES 5000

Labelling system for marking and traceability

✓ Consumables

R-ID Clip: S, M

⏻ Function and operation

The automatic double clipping machine is connected mechanically and synchronized electrically to a filling machine. The portions are fed in precisely to the nearest gram and closed by a clip. The PC control allows a very fast and accurate signal processing. On the SAFETY TOUCH display the diagnostic system provides a direct and clear indication of the clipping machine's operational status as well as a clear error message.

A high degree of process monitoring is offered by the FCA's automation. In case of deviations from the recipe parameters saved in SAFETY TOUCH a warning is automatically displayed. The operator is intuitively guided through the flat menu structure of the SAFETY TOUCH by means of self-explaining pictograms. Operator, set-up and service levels are kept clearly separated and are password protected. The automated operation offers the greatest product safety and maximum efficiency.

✓ Clip system solutions

The complete system of clipping machine, clips and loops from a single source ensures efficient and trouble-free production. Original clips from Poly-clip System guarantee the highest quality. Manufacturing is subject to the most rigorous quality controls. Certified in accordance with ISO 22000 and ISO 9001 they are designed to suit the production process perfectly. With its food-proof safety coating certified by the SGS INSTITUT FRESENIUS, Poly-clip SAFE-COAT technology ensures trouble-free production and if required a no-worry

product warranty. Poly-clip System is the world's leading provider of clip system solutions.

The FCA series with smooth surfaces of stain less steel for ease of cleaning



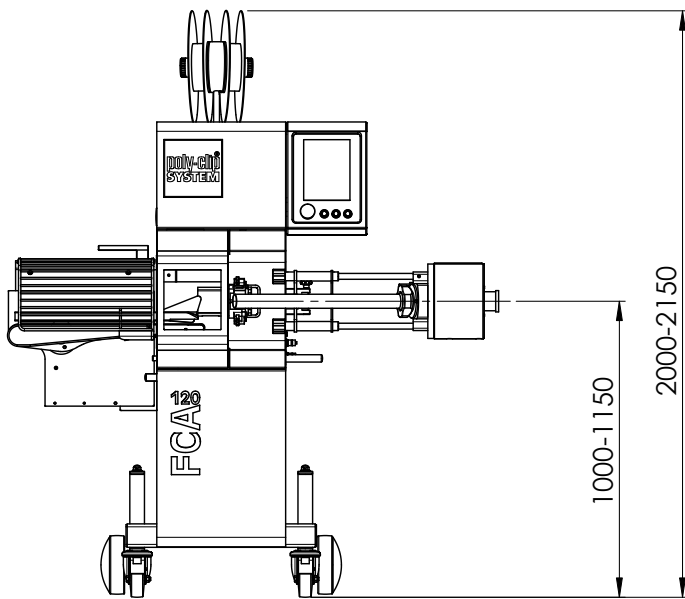

Front view (Dimensions in mm)

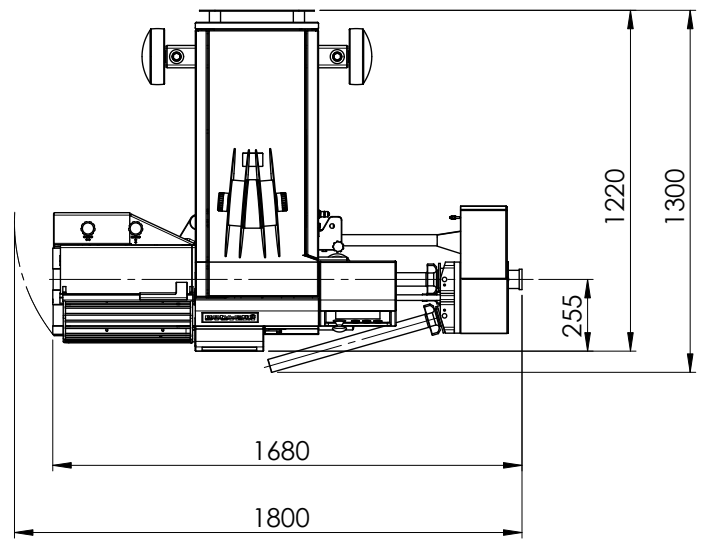

Top view (Dimensions in mm) Length of stuffing horn 600

Technical data

Width	1,680–1,800 mm
Depth	1,220–1,300 mm
Height	2,000–2,150 mm
Weight	640 kg
Three-phase current connection	200–480 VAC, 50/60 Hz
Power input	3 kW
Fuse connection	16 A
Compressed air	5–7 bar / 0,5–0,7 MPa
Air consumption	1.6 NL/cycle
Spreading	18, 26, 30 mm
Total spreading up to	130 mm

Dimensions, weight and consumption values vary depending on the equipment and/or machine configuration.