



### Medium automation

- For the 24 – 90 mm calibre range at up to 186 cycles per minute in continuous mode
- Shortest down-time for reloading of casing and maintenance, with even higher safety
- Fully hygienic conveyor belt, dismantling without tools
- Optimal accessibility for ease of cleaning

### Why clip with FCA 100?

High production speed at up to 186 cycles per minute for small and medium-sized calibres as well as shortest downtimes distinguish the FCA 100. The automatic double-clipper closes collagen and fibrous casings up to 58 mm and plastic casings up to 90 mm in diameter (depending on the material thickness).



### Advantages

- Safety casing brake with hand guard; maintaining safety distance to separator when adjusted, operation without casing brake is blocked
- R-ID Clip with high holding force, even up to bacteria-proof clip closure with plastic casings
- Incorrect settings are avoided by detection of the clip size and die
- Auto-Stop System, clip sensor monitoring end of clip supply on reel
- Quick-change system for punch and die without tools
- Operator-friendly with individually assignable manual functions, e.g. inching mode
- Comfortable external adjustment of the clip pressure and separator hole, without tools
- Short sausage ends, uniform pleating and clean sausage tails due to the linear voiding separator
- Highly dynamic, energy-efficient servo drive, infinitely adjustable speed
- Highest productivity; product parameters can be recalled



from the SAFETY TOUCH recipe management

- Simple machine operation with SAFETY TOUCH – shockproof, 10" large and easy to clean
- Electronic hand-wheel for



Fully hygienic conveyor belt, dismantling without tools



Casing brake assistant – semi-automatic casing brake holder system

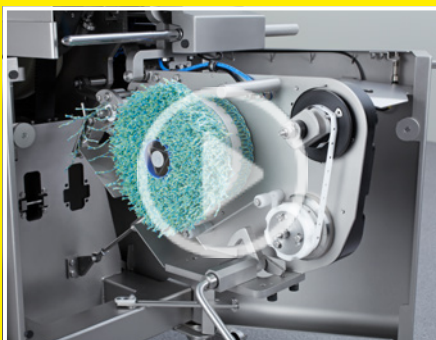

Retractable automatic looper GSA for easy reloading of loops



Separator cleaning flap

- Easy to clean due to smooth surfaces, large openings, front flap and the special separator cleaning position
- Separator cleaning flap – allows ideal accessibility

### ✓ Maintenance

- Centralized lubrication strip for easy and fast maintenance
- Maintenance- and service-friendly with few wearing parts, easily accessible by swing-off side covers

### + Optional equipment

- Consumption-oriented central lubrication for maximum reliability and service life
- Fully hygienic conveyor belt, dismantling without tools, single lane 700 or 1200 mm, double-belt 700 mm and roller extension
- Casing brake assistant – semi-automatic casing brake holder system for fastest reloading of casings
- Casing end sensor
- Sensor for end of loop supply
- Pneumatic dry sausage brake, individual control of the twin turret's casing brakes as product parameter via SAFETY TOUCH
- Automatic looper GSA 20, loop left or right
- Air-free slack filling of moulded products by overspreading, sensor monitored total spreading up to 100 mm, comfort setting in front
- Twin turret with swivel horns and 90° pivot point
- Length portioning by optical sensor or mechanical length stop 1,000 mm and 1,350 mm
- Ball joint filler connection
- String dispenser for rings
- Print mark control for centred printing format
- Intelligent Filler Clipper (IFC) Interface upon request

adjustments and setting parameters

- Swivel horn, twin turret and casing brake assistant with 90° pivot point
- Low noise level
- Processes high-quality clips – certified safe for use with food by SGS INSTITUT FRESENIUS
- Clip and loop manufacture

certified in accordance with ISO 22000

- USB port for data import and export

### ✓ Quality and hygiene

- Robustness and long service life guaranteed by use of stainless steel and titanium

## **Combinability**

### **ES 5000**

Labelling system for marking and traceability

## **Consumables**

R-ID Clip: S, M

## **Function and operation**

The automatic double clipping machine is connected mechanically and synchronized electrically to a filling machine. The portions are fed in precisely to the nearest gram and closed by a clip. The PC control allows a very fast and accurate signal processing. On the SAFETY TOUCH display the diagnostic system provides a direct and clear indication of the clipping machine's operational status as well an analysis of filling and clipping times. Deviations from the recipe parameters saved in SAFETY TOUCH are monitored. The operator is intuitively guided through the flat menu structure of the SAFETY TOUCH by means of self-explaining pictograms. Operator, set-up and service levels are kept clearly separated and are password protected. A high degree of process monitoring is offered by the FCA's automation.

## **Clip system solutions**

The complete system of clipping machine, clips and loops from a single source ensures efficient and trouble-free production. Original clips from Poly-clip System guarantee the highest quality. Manufacturing is subject to the most rigorous quality controls. Certified in accordance with ISO 22000 and ISO 9001 they are designed to suit the production process perfectly. With its food-proof safety coating certified by the SGS INSTITUT FRESE-

NIUS, Poly-clip SAFE-COAT technology ensures trouble-free production and if required a no-worry product warranty. Poly-clip System is the world's leading provider of clip system solutions.



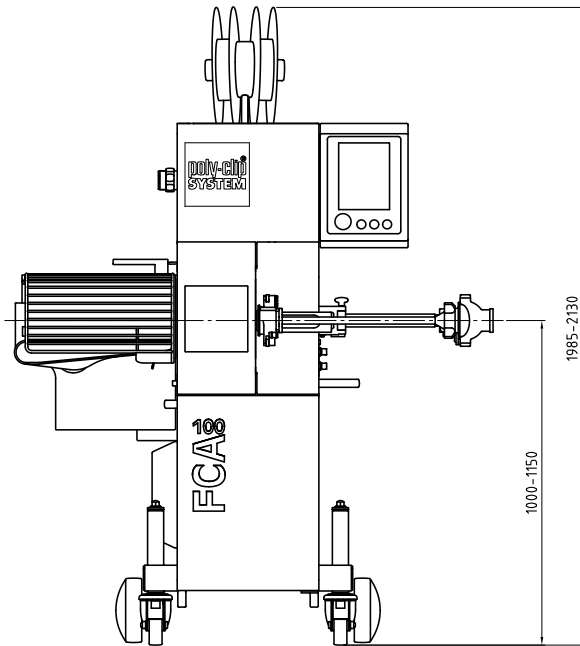

Front view (Dimensions in mm)

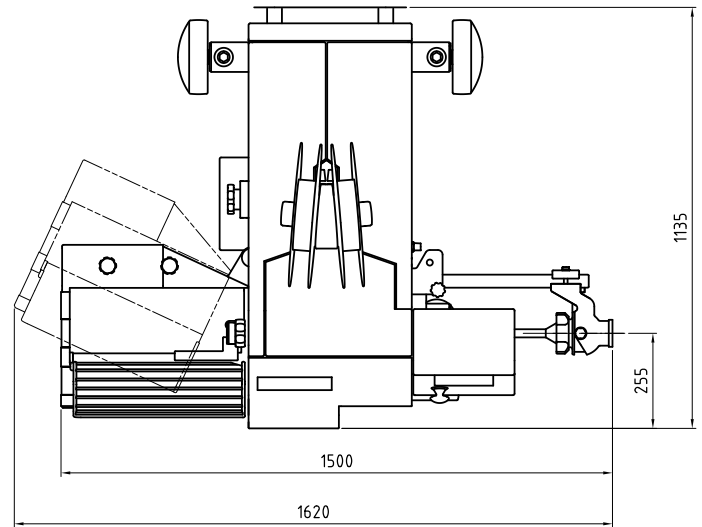

Top view (Dimensions in mm) Length of stuffing horn 600

### Technical data

Width	1,500–1,620 mm
Depth	1,135 mm
Height	1,985–2,130 mm
Weight	550 kg
Three-phase current connection	200–240 VAC, 380–460 VAC, 50/60 Hz
Power input	4 kW
Fuse connection	16 A
Compressed air	5–7 bar / 0,5–0,7 MPa
Air consumption	2.5 NL/cycle
Spreading	18, 26, 30 mm

Dimensions, weight and consumption values vary depending on the equipment and/or machine configuration.